

**ApolloSpray**  
**2 Quart (2 Liter)**  
**Fluid Feed System**  
**(A4500)**

**Assembly & Instruction Manual**



***Apollo Sprayers International, Inc.***

***1030 Joshua Way, Vista, CA 92081***

***(760) 727-8300***

***(888) 900-HVLP (4857) Sales***

***(760) 727-9325 Fax***

***www.hvlp.com***

# Table of Contents

Unpacking.....	3
Attaching the turbine.....	4
Converting your spray gun.....	5
Connecting the hoses.....	6
Preparing to spray.....	7
Setting pot pressure.....	8-9
Cleaning your system.....	10
Fluid feed system diagram #1.....	11
Fluid feed system parts list #1.....	12
Spray gun diagram #2.....	13
Spray gun parts list #2.....	14
Pressure pot diagram #3.....	15
Pressure pot parts list #3.....	16

## Unpacking

Remove contents of shipping box and lay out all of the pieces. The box should contain the following items:

1. The compressor deck (assembled)
2. 2 Quart (2 liter) pressure pot with regulator, gauge, safety valve and connectors attached
3. 1/4" X 20' black, lined fluid hose
4. 4 wheels and hardware
5. This instruction manual

**Note:** This system is designed for compatibility with Apollo Turbine Models 700, 800, 900, 1000, 1100. The A4500 is designed to bolt onto Apollo Models 800, 900 and 1000 becoming an integral part of the system. The A4500 will work alongside Apollo models 700 and 1100 and any other brand of HVLP.

You will need to have a few tools handy. Below we have provided a small list of things to have handy before you begin to assembly your system.

1. 2 X 7/16" wrenches
2. 1 X 1/4" wrench
3. 1 X 3/4" wrench
4. Locking Pliers
5. Teflon Tape
6. Standard screwdriver

## Attaching the Turbine

1. Remove the stainless steel carry handle from the top of the turbine unit. To remove the handle you will need a pair of locking pliers. Grip the cap on one end of the handle (either side). Twist back and forth to loosen. The cap is installed with Lock-Tite so it will be necessary to break the seal. The cap is not threaded so it is safe to twist back and forth until it comes off.

**Tip:** If you have a blow torch you can heat up the cap a little bit and loosen the Lock-Tite. Be careful not to heat too much or you will damage the paint on the case.

You only need to remove one side. Once the cap is removed, carefully pull the handle through the opposite end and store in a safe place.

2. Remove the six nuts and bolts on the top of the turbine using 2 X 7/16" wrenches.
3. Remove the top of your turbine by pulling up on the inside edge of the top. Sometimes it helps to put a screwdriver through one of the six bolt holes and push gently down.
3. Remove the four bolts (Diagram 1, #3,4,5) that secure the pressure pot support bracket (Diagram 1, #14) to the compressor deck (Diagram 1, #1) using a 2 X 7/16" wrenches.
4. Place the compressor deck on top of the turbine and align the three holes on each side. Secure the deck with the nuts, bolts and washers you removed from your turbine top.
5. Place the 2 Quart (2 Liter) Pressure Pot (Diagram 1, #16) into the pressure pot support bracket (Diagram 1, #14).
6. Install the 4 wheels supplied into the four holes on the turbine unit base. (Older turbine models will need four wheel holes to be drilled in the base. Request the dimensions from the factory).

## **Converting your Spray Gun**

1. Disconnect the upper section of the air feed tube from the non-return valve (Diagram 2, #25) leaving the valve attached to the lower section of the tube. This will provide safe storage while using the spray gun in the production mode.
2. With a  $\frac{3}{4}$ " open end wrench, loosen the Center Bolt (Diagram 2, #26) and remove the entire cup assembly. Set aside.
3. Remove the air feed connector (Diagram 2, #8) along with the upper section of the air feed tube using a small open end  $\frac{1}{4}$ " wrench. Install the blanking screw, provided in the plastic bag ( $\frac{10}{32}$ ") to close the hole where you removed the air feed connector. Store the air feed connector with tube attached in the cup assembly for future use.

## **Connecting the Hoses**

1. Attach the turbine air hose to handle of spray gun with the quick disconnect coupler (Diagram 2, #21).
2. Insert the male coupler on the other end of the air hose into the quick disconnect coupler on the turbine unit. Refer to turbine manual for additional details.
3. Locate the fluid connector (Diagram 2, #35) on the underneath of the spray gun and wrap a strip of Teflon tape around the threads. Also wrap a strip of Teflon tape around the threads on the fluid reducer.
4. Screw on the 3/8" – 1/4" reducer, unless you are using 3/8" fluid hose, in which case you don't need to use the reducer.
5. Screw one end of the Black fluid hose onto the Fluid Connector. Secure and tighten.
6. Locate the Fluid Outlet on the lid of the 2 Quart (2 liter) pressure pot (Diagram 3, #3) and wrap a strip of Teflon tape around the threads.
7. Attach the remaining end of the black fluid hose to the fluid outlet (Diagram 3, #3). Secure and tighten.
8. Locate the small black air compressor (Diagram 1, #2) mounted on the compressor deck (Diagram 1, #1). Connect the female quick disconnect (Diagram 1, #12) on the air hose from the compressor to the male quick connect on the pressure pot.
9. Your Fluid Feed System is now set up for production spraying.

## Preparing to Spray

**Caution: Never open the pressure pot without turning off the air compressor and releasing the air pressure in the pot with the Air Pressure Release Valve. (Open valve until all pressure is released. Pressure Gauge will read “0 PSI” when there is no more pressure in the pot).**

1. Prepare your paint or coating for spraying. Adjust viscosity as recommended. Refer to Turbine instruction manual for viscosity guidelines.
2. Unscrew the Cup Top (Diagram 3, #4) on the 2 Quart (2 Liter) pressure pot. (Turn anti-clockwise).

**Note:** You may have to disconnect the air hose from the compressor when opening the lid. Be sure to reconnect air hose when the lid is closed again.

3. Pour your coating into the pot
4. Screw the lid back on top of the pressure pot making sure that the pot is properly seated on the gasket.
5. Plug the Power Cord from the small black compressor (Diagram 1, #2) into a proper grounded receptacle outlet. **Caution:** If you are using an extension cord, it is imperative to use at least a 12 gauge cord to avoid damage to electrical components.

## **Setting Pot Pressure**

6. Turn on the mini-compressor unit (Diagram 1, #2). Locate the on/off switch which is mounted on top of the silver box on the side of the compressor. Move the switch to the “on” position. You should hear the compressor begin to pressurize the pot..
7. Look at the pressure gauge (Diagram 3, #15) located on top of the cup top (Diagram 3, #4). You will notice the gauge begin to rise as the pressure builds in the pot. The pressure gauge will tell you how much air pressure is in the pressure pot. Generally you will only need about 5 PSI for most light to medium viscosity fluids. Increasing pressure should only be necessary for high viscosity fluids or when the fluid must travel up hill for more than 10 feet.
8. Attached to the pressure gauge is the pressure regulator (Diagram 3, #7). To decrease pressure, rotate the knob on the pressure regulator anti-clockwise. To increase pressure rotate the knob clockwise. Stop when the desired pressure is achieved. Your compressor is set to shut off when the desired pressure is reached and back on when the pressure drops down. This has been pre-set at the factory and should not be readjusted.
9. If the pressure rises above the desired maximum, you can release pressure in the pot with the Air Release Valve (Diagram 3, #8) and control the maximum amount of pressure with the Pressure Regulator (#7).



**Note: Items 10 and 11 should NOT be performed with the turbine on.**

10. When the air pressure in the pot has been set at the desired pressure and the fluid has been added to the pressure pot, pull the trigger back on the spray gun. (**Caution: Don't point the spray gun at yourself or anyone else, you can cause bodily injury. Make sure that you hold the gun safely away from you.**) The first time you use the pressure pot each day, or after the pressure pot has been depressurized, it will take a minute or two for the fluid to reach the spray gun. When the fluid reaches the tip of the spray gun a stream of fluid will flow out. This is known as "Priming" the spray gun.
11. A good indication of pot air pressure can be determined by observing the fluid stream from the spray tip (Diagram 2 #6). When the trigger is pulled without the turbine running the fluid stream should extend out 2 1/2" (6.35cm) before the stream begins to bend. If the fluid extends further than 2 1/2", then you have too much air pressure. If it is shorter than 2 1/2", then you need more air pressure. Adjust accordingly.
12. Turn on the turbine system. You should now be able to spray continuous volume from the pressure pot.

**Note: Never open the pressure pot without turning off the air compressor and releasing the air pressure in the pot with the Air Pressure Release Valve. (Open valve until all pressure is released. Pressure Gauge will read "0 PSI" when there is no more pressure in the pot).**

## Cleaning the System

1. When you are finished spraying for the day, it is wise to clean your spray gun, the pressure pot and the fluid line. While it is possible to leave fluid in the pressure pot between uses, be sure that all materials are compatible with the components of the pressure pot to avoid fluid contamination. Never leave catalyzed or epoxy materials in the pot beyond suggested pot life of the fluid product to avoid set up and hardening of the coating and damage to the pot, its components, fluid lines and the spray gun.
2. Release all air pressure in the pot. Locate the Air Release Valve and turn anti-clockwise. You will hear hissing. The pressure in the pot is now releasing. You will also notice that pressure gauge will lower to "0 PSI". Once there is no more pressure in the pot, it is safe to open.
3. Following normal cleaning procedures of the spray gun as outlined in the Turbine instruction manual and information supplied with the spray gun.
4. Clean pressure pot and fluid lines with appropriate cleaning materials for the product being sprayed, exercising all cautions depending on the cleaning material being used. Spray cleaning fluid from the pressure pot through the fluid line and the spray gun until you are satisfied that all paint or coating material has been flushed through the system.
5. Store equipment for use in the future.

**TIP:** To easily remove the fluid in the fluid hose without wasting any, cup your hand over the front of the spray gun. With the pot air pressure at "0" psi and the turbine running, pull the trigger. The turbine air will be forced through the spray tip into the fluid passages and hose, pushing the remaining material back into the pot.

# Diagram 1

*Model A4500*

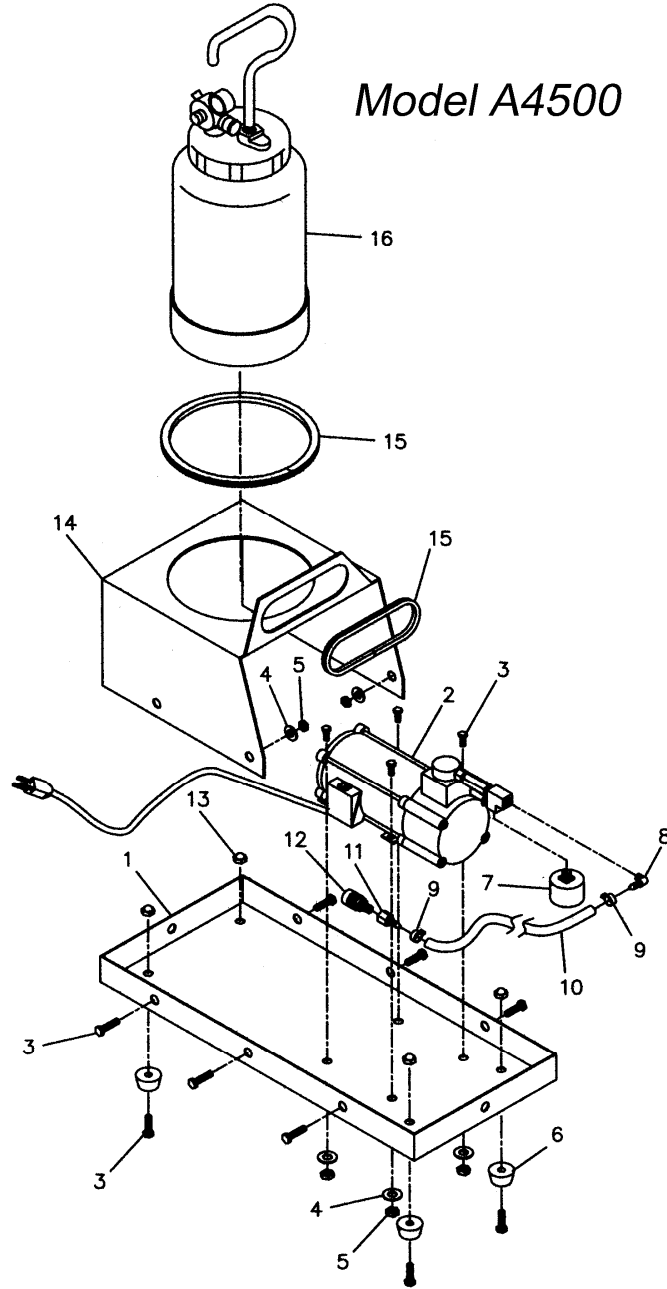

## Parts List 1—Fluid Feed System

Diagram #	Part #	Description	Quantity
1	A4501	Compressor Deck	1
2	A4198	110V mini compressor unit	1
3	A4320	1/4" x 20 x 1/2" hex bolt plated .5.	12
4	A4300	1/4" SAE F/W plated washer	16
5	A4308	1/4" X 20 hex nuts plated	4
6	A9016	Rubber Foot	4
7	A4998	Pressure regulator	1
8	A4503	1/8" male NPT X 1/4" male hose barb 90°	1
9	A4033	Air line hose clip S.S.	2
10	A2116	1/4" air hose, per foot	3
11	A2119	1/4" X 1/4" female swivel barb	1
12	A4026	Quick connect female with 1/4" male thread	1
13	A4310	1/4" X 20 cap nut plated	8
14	A4502	Pressure pot support bracket	1
15	A4613	Rubber edge trim	2
16	A4200	2 quart pressure pot w/single regulator	1

# Diagram 2

## MODEL A 5010 (Quick Release Cup)

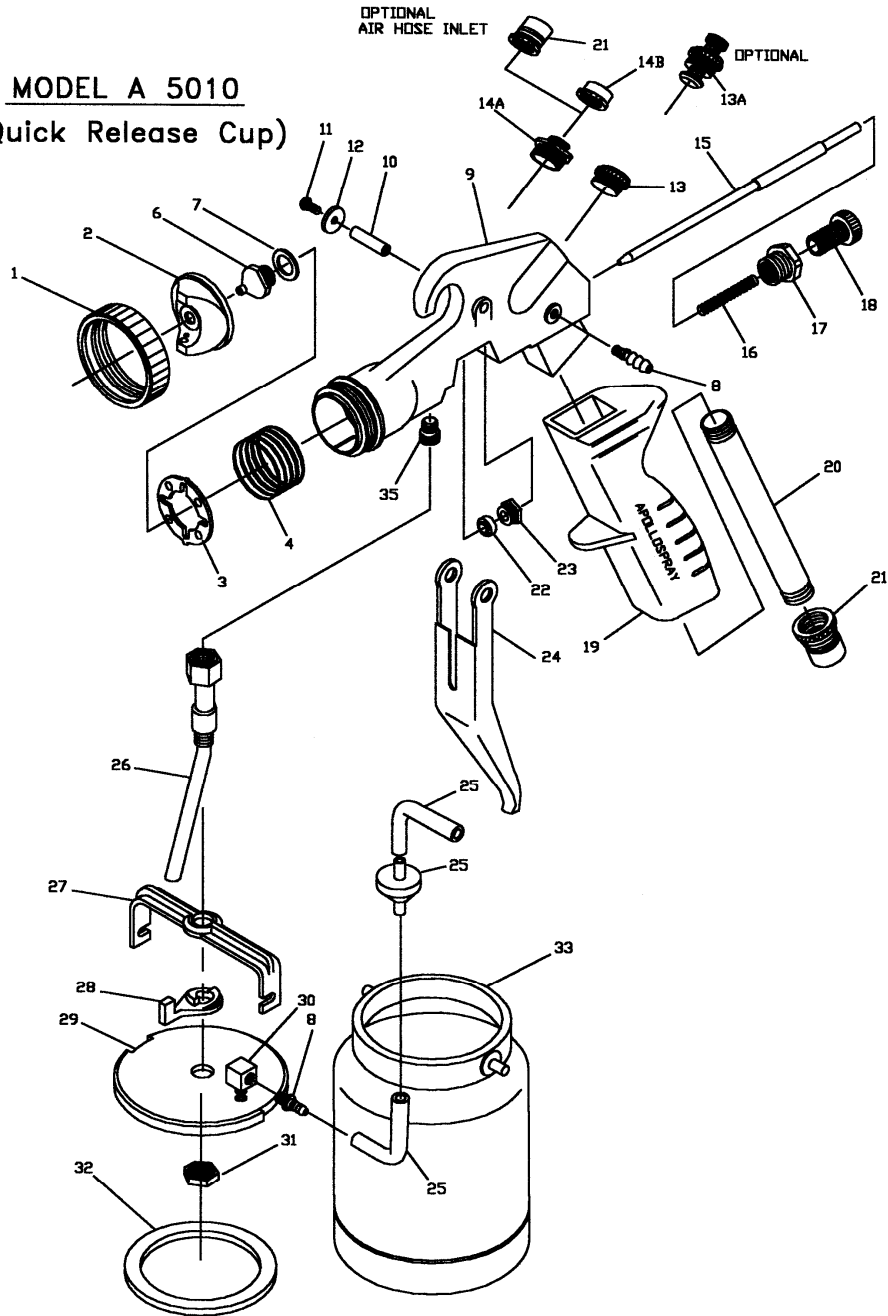

## Parts List 2

Diagram #	Part #	Description
1	A5200	Air cap ring
2	A5201	Air cap # 1
2	A5297	Air cap # 2
3	A5203	Air distributor plate (stainless)
4	A5204	Air distributor spring (stainless)
6	A5206	Fluid nozzle/jet (stainless) .75MM
6	A5207	Fluid nozzle/jet (stainless) 1.00MM
6	A5208	Fluid nozzle/jet (stainless) 1.50MM
6	A5208-2	Fluid nozzle/jet (stainless) 2.00MM
6	A5209	Fluid nozzle/jet (stainless) 2.50MM
7	A5210	Fluid nozzle gasket
8	A5211	Air feed connector
9	A5212	Gun casting (main body)
10	A5213	Trigger bushing
11	A5214	Trigger pivot screw (stainless)
12	A5215	Trigger screw washer
13	A5202	Air blanking plug
13a	A5257	Air control texturing valve
14a	A5216	Upper port insert
14b	A5217	Air blanking plug
15	A5218	Needle (stainless) .75MM
15	A5219	Needle (stainless) 1.00MM
15	A5220	Needle (stainless) 1.50MM
15	A5220-2	Needle (stainless) 2.00MM
15	A5221	Needle (stainless) 2.50MM
16	A5222	Needle spring (stainless)
17	A5223	Flow screw insert
18	A5224	Material flow adjusting screw
19	A5225	Gun casting (handle)
20	A5226L	Handle tube
21	A5227	Air hose quick release coupler (male)
22	A5228	Gland seal
23	A5229	Gland seal (stainless)
24	A5230	Trigger (stainless)
25	A5232	Air feed tube and non-return valve
26	A5274	Center bolt/pick-up tube
27	A5271	Yoke
28	A5278	Lever
29	A5270	Cup top casting
30	A5266	90 degree miniature brass block
31	A5272	Cup top lock nut
32	A5280	Cup top gasket (White poly)
33	A5275	Quick release cup
33	A5277	Quick release cup (Teflon coated)
35	A5254	Fluid connector 3/8" (stainless)

### Diagram 3

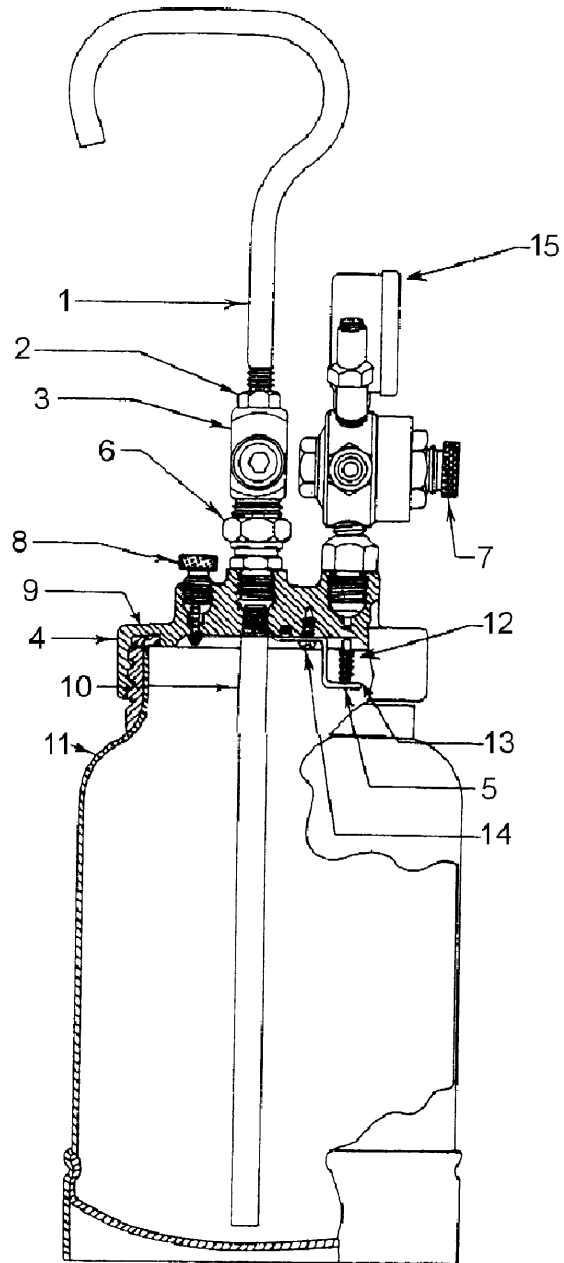

15

## Parts List 3

<b>Diagram #</b>	<b>Part #</b>	<b>Description</b>	<b>Quantity</b>
1	A4601	Handle, 2 qt. p/pot	1
2	A4602	Handle lock nut	1
3	A4603	Fluid Outlet	1
4	A4604	2 Quart Cup top Casting	1
5	A4605	Check valve	1
6	A4606	Centerpost	1
7	A4607	Air regulator assembly	1
8	A4608	Relief valve stem	1
9	A4609	Cup top gasket	1
10	A4610	Material pickup tube, S.S.	1
11	A4611	2-quart cup with Teflon	1
12	A4612	Check valve spring	1
13	A4613	Check valve bracket	1
14	A4614	Check valve screw	1
15	A4914	Pressure Gauge	1